

# Arkansas State Horse Show Association

2009

## BYLAWS, RULES, & REGULATIONS

### INDEX

	Page
Officers.....	1
Committees.....	1
Annual Meetings.....	1
Membership.....	2
Age Divisions.....	3
Entries/Entry Fees/Stall Money.....	3
Trophies/Awards.....	4
Association High Point.....	5
Individual High Point.....	5
Announcer.....	6
Sportsmanship Rules.....	7
Miscellaneous Rules.....	7
Timer Failure.....	9
Announcers Stand.....	9
Drug Policy.....	9
Coggins.....	11
Mandatory Classes.....	11
Judged Events.....	12
Speed and Timed Events.....	17
Flag/Speed/Keyhole Diagram.....	23
Reining Patterns.....	24

## ARKANSAS STATE HORSE SHOW ASSOCIATION RULES & REGULATIONS

The official name of the Association shall be Arkansas State Horse Show Association and shall be at all times operated and conducted as a non-profit association in accordance with the laws of the State of Arkansas providing for such organizations and by which it shall require all such rights as granted to associations of this kind.

The purpose of this Association shall be to stage an annual Championship Horse Show in the State of Arkansas for qualifying riders from member associations.

### OFFICERS

**CHAIRMAN:** Shall be elected by the Board from member associations at the annual meeting in October. He or she shall preside at all meetings, appoint committees, and see that all rules and regulations are enforced. Motel expenses shall be paid by the State Association.

**VICE CHAIRMAN:** Shall be elected the same as the Chairman. He or she shall preside in the absence of the Chairman and assist in performing duties, etc. Motel expenses shall be paid by the State Association.

**JUNIOR PAST CHAIRMAN:** Position held by outgoing Chairman. This position shall be a non-voting, advisory position assisting the Chairman.

**SECRETARY-TREASURER:** Shall be appointed by the elected Chairman. Shall keep all minutes of the meetings and other records pertaining to the Association. Shall disburse money under the discretion of the Chairman. Shall be responsible for notifying board members of meetings, accepting entries for the State Show, furnishing financial statement at the end of the year, etc. Motel expenses shall be paid by the Association.

**BOARD OF DIRECTORS:** Shall consist of the elected presidents of each member association. If an association chairman or vice chairman is not able to attend a board meeting, a letter or phone call indicating who will vote for the association must be received by the State Chairman.

### COMMITTEES

As appointed by the Chairman.

### ANNUAL MEETINGS

The Board of Directors of the Arkansas State Horse Show Association shall hold a meeting in October to elect a Chairman and a Vice Chairman. The officers' terms shall run from

October to October. Proposed rule changes for the following year will be brought up at the October meeting and will be voted on at the January meeting, and all rule changes regarding events will be finalized by the February meeting. Other meetings may be scheduled by the Chairman as deemed necessary in order to finalize plans for the State Show, etc.

If 75% of the Board of Directors feels the Chairman is not functioning, a meeting can be called by the Board to question the Chairman or elect a new Chairman.

### MEMBERSHIP

Membership shall consist of approved associations in the State of Arkansas.

Annual dues are \$100 per association or as otherwise passed by the Board of Directors and are payable at the first State meeting in January of each year. These dues will be used as a starter fund in making preparations for the State Show and will be refunded to each association at the end of each year when proceeds from the State Show are distributed.

Association sponsorship fees are \$300.00 and are payable by June 15 to State Secretary or Treasurer.

Minimum guidelines for accepting new associations into the Arkansas State Horse Show Association are as follows:

1. Must hold a minimum of six (6) shows during the season.
2. Must have at least one full season behind them as an association when applying for membership.
3. Must submit a report showing the association is financially solvent from shows during the past season(s); this will be determined by the Board.
4. Must have an average of at least 200 entries per show.
5. Must offer at least 75% of the events on the State Show program and must agree to have as many of the remaining State Show events as possible.
6. Must have association rules as close to the State Show rules as possible.
7. When applying for membership, the association must bring information supporting the above statements when appearing before the Board so they will have sufficient information on which to base their vote.
8. Any new association coming into the state association will be on a 5-year probation with a board review to see if it is meeting qualifications every year on an annual basis.

## AGE DIVISIONS

Pee Wee highpoints will be calculated only in the following events: walk-trot, pony barrels, pony pole bending, and pony class.

Buckaroo – 13 years and under

Junior – 18 years and under

Senior – 19 years and over

Riders must ride in only **ONE** age division when there are specific classes limited to their age division, i.e., junior poles and buckaroo poles, etc.

The age of an individual on January 1 of that year shall be maintained throughout the entire year.

Riders in the buckaroo and junior age groups will not be allowed to show a stallion in judged event, including Queens' Class and Pony Class; the exception will be in Junior Reining. Riders in the buckaroo and junior age groups will be allowed to ride a stud in speed events.

## ENTRIES/ENTRY FEES/STALL MONEY

The entry fee shall be voted on by the Board.

Each association may enter its **TOP FIVE** riders in each class. **EXCEPTION:** Barrel Pick-Up. (In some associations the situation arises where by a contestant will end up in the top five as both rider and jump man. Should this happen, a choice will have to be made by the contestant as he may enter **ONLY ONE TIME** in the class; he may enter as a rider or a jump man, but not as both.)

Contestants must represent only **ONE** association for all events at the State Horse Show.

All contestants must ride in 50% of their association shows in order to be eligible to compete in the State Horse Show.

An association may not borrow riders from other associations in order to fill its classes.

Each association president is responsible for verifying that entries are correct and sent to the State Secretary by the designated deadline. No changes on the entry sheets for the Friday show will be accepted after 3:00 p.m.. No changes on the entry sheets for the Saturday show will be accepted after the show begins on Saturday. The same shall apply

to Sunday and Monday Shows. Scratches can be made at any time. Each association must pay for five (5) places in each event whether or not it has five entries.

Each association is responsible for paying for assigned stalls at the fee set by the Board.

All entry fees and stall money are due in advance and must be included with entries when sent to the State Secretary.

Each person entering the State Horse Show must sign a Consent Waiver, and Release Form. This form must accompany the entry sheets sent to the State Secretary.

### TROPHIES AND AWARDS

Ten places in each class are to be awarded if applicable. Trophies will be in accordance with the Arkansas Sate Horse Show Association trophy specifications. These areas follow:

#### Quarter Classes

##### 1<sup>st</sup> thru 5<sup>th</sup> Places

Type of Horse: 9 ½ X 7” Metal Handcast Quarter Horse  
Base: 5 X 9 ½ X 1 ¾” Solid Walnut Base with slant front  
Other: 3 X 9” White Marble on 1<sup>st</sup> place only  
Finish: Gold

##### 6<sup>th</sup> thru 10<sup>th</sup> Places

Type of Horse: 7 ¼ X 5 ¼ ” Metal Handcast Quarter Horse  
Base: 4 ¼ X 7 X 1 ¾” Solid Walnut Base with slant front  
Other: 3 X 9” White Marble on 1<sup>st</sup> place only  
Finish: Gold

#### Gaited Classes

##### 1<sup>st</sup> thru 5<sup>th</sup> Places

Type of Cup: 9 ½” Anodized Spun Aluminum Cup with Handcast Urn  
Type of Horse: 5 ½” Tennessee Walking Horse (plastic)  
Base: 9 X 9 X 1 1/8” Wood Base with Walnut Grain Finish  
Finish: Gold  
Other: 5” Round Onyx on 1<sup>st</sup> Place only  
4 – 3 ½” Metal Eagle Trim on 1<sup>st</sup> Place  
4 – 2 3/8” Metal Eagle Trim on 2<sup>nd</sup> – 5<sup>th</sup> Places

##### 6<sup>th</sup> thru 10<sup>th</sup> Places

Type of Cup: 6 ¾ ” Anodized Spun Aluminum Cup with Handcast Urn  
Type of Horse: 5 ½” Tennessee Walking Horse (plastic)  
Base: 6 ½ X 6 ½ 9 X 2 1/8” Wood Base with Walnut Grain Finish

Finish: Gold  
Other: 4 – 2 3/8” Metal Eagle Trim

Inscription on awards: Gold nameplates with notched corners; Black sublimated lettering.

### ASSOCIATION HIGH POINT

A new championship trophy will be bought each year and awarded to the high point association. Duplicate awards will be given in the event of a tie between associations. The Secretary shall total the points earned in each class and announce the winner at the end of the State Show.

All mandatory classes will be considered in the computation of points. Any optional events added by the Board are not to be considered in the total. Barrel Pick-Up will be considered as one class.

Computation of points is to be as follows:

1 <sup>st</sup> place – 10 points	6 <sup>th</sup> place – 5 points
2 <sup>nd</sup> place – 9 points	7 <sup>th</sup> place – 4 points
3 <sup>rd</sup> place – 8 points	8 <sup>th</sup> place – 3 points
4 <sup>th</sup> place – 7 points	9 <sup>th</sup> place – 2 points
5 <sup>th</sup> place – 6 points	10 <sup>th</sup> place – 1 point

### INDIVIDUAL HIGH POINT

High point awards will be given to the high-point buckaroo, junior, and senior rider scoring according to the Board’s discretion. A peewee award may be given at the Board’s discretion.

If give, the following rules will apply:

1. All contestants must compete in more than one event at the state level.
2. Queen’s Class will not be counted toward the individual high point.
3. Walk-Trot, Pony Class, Pony Barrels, and Pony Poles will count toward individual high point only if there is a pee-wee high point award.
4. Highest number of points in at least two classes will determine the winner. Points will be based on the same system as points for association high point.
5. In case of a tie, the contestant will be declared a winner who
  - (a) earned the most points in the greatest number of events,
  - (b) had more first, seconds, thirds, fourths, fifths, etc
  - (c) earned the most points over the greatest number of other competitors.

## JUDGES

The point system will be utilized by the judges in all judged events with the exception of gaited classes.

The judges will be hired by a committee appointed by the Chairman to hire judges in February and March for the following year.

A judge that shall judge the Arkansas State Horse Show shall not have judged the Arkansas State Horse Show for the previous three years. In addition he/she shall live a minimum of 100 miles from any show (i.e. AQHA, 4-H, or breed show of any kind) in the state of Arkansas during the calendar year that he/she is judging the Arkansas State Horse Show.

The committee shall send a copy of the official rules at least thirty (30) days prior to the State Show.

A written confirmation should be returned to the Judge Committee Chairman by the judges.

Judges are responsible for insuring that only qualified persons participate in the work off and will be assisted by the State Secretary. The judge will be so informed before the starting of the show by the State chairman. If a person enters the work off who should not be in the arena, the judge will call his/her number out and ask him/her to leave.

A signed copy of the judge's score cards will be posted after each event. The scores will be announced for reining and horsemanship patterns after each rider. When two judges place riders in an event, the winners will be tabulated according to a 10 through 1 system. In case of a tie, the head judge's score will be used to break the tie.

## ANNOUNCER

The announcer shall keep a copy of the official Rules and Regulations before him at all times.

The announcer is to ask the audience to keep the noise down during all pleasure classes.

The announcer shall make every effort to expedite the show in every way

In case of a dispute on entries, work off contestants, etc. the announcer shall refer it to the State Chairman and/or Board rather than make a decision himself.

## SPORTSMANSHIP RULES

A contestant or member of his/her immediate family deemed guilty of misconduct or unsportsmanlike conduct in the opinion of a majority of the Board of Directors shall be penalized by any or all of the following.

1. Contestants will be immediately suspended from further participation in the State Show.
2. Contestants and/or his/her immediate family will forfeit any points earned and forfeit all entry fees.
3. Contestants and/or his/her immediate family will be suspended from participation in the first three (3) shows of his respective association in the following show season.
4. Contestant and/or his/her immediate family will be suspended from the next State Show.
5. The Board of Directors will deal with the violation according to the severity of the situation.
6. Any person wishing to appear before the ASHSA Board of Directors to appeal disciplinary action taken against them under the Sportsmanship Rules must post a \$250.00 cash bond to the Board prior to appearing. This bond will be refunded if the Board of Directors rules in favor of the appellant.

Each association president is responsible for insuring his/her membership complies with the above sportsmanship rules.

## MISCELLANEOUS RULES

All association presidents will make every reasonable effort to insure their membership is award of the rules contained within and is responsible for compliance to include sportsmanlike conduct.

Horses will be checked at the State Show for illegal drugs; all details are included in the ASHSA Drug Policy.

Working order for the arena will be drawn for the last Board meeting before the State Show.

A rider may compete only **ONE** time in a class; a horse may be ridden only **ONE** time in a class.

Running order of associations in speed events shall be drawn at the last Board meeting before the State Show. Running order shall be rotated as follows: each association will move up one position with each speed event run (i.e. an association drawing position number one will move down to last for the second speed event; an association drawing position number two will move up to number one for the second speed event, etc.)

The arena will be dragged after two associations in every speed event at the State Show.

Assistance in the gate (rope for pleasure, gate for speed) in all events will be allowed.

Every rider at the State Show shall wear boots, or “heels down” shoes while participating at the State Show with the exception of the jump man in Barrel Pick-up. Special consideration may be made at the Board’s discretion.

Horses staying overnight at the Coliseum must be stalled. Only **ONE** horse per stall is allowed. Stalls cannot be changed after assignments are made. **NO TACK STALLS ALLOWED AT THE STATE SHOW.**

No motorcycles, bicycles, 4-wheelers, 3-wheelers, scooters, mopeds, etc are allowed on coliseum grounds.

No dogs are allowed on the coliseum grounds without a leash.

No fifth place ties will be honored as of 1997 Arkansas State Horse Show.

Only five horses per class will be allowed from each association.

Final work offs will be limited to no more than twenty-five (25) horses.

No lounging of horses will be allowed in the show arena or in the warm up area.

The arena where running patterns are set will be worded prior to the event.

Workers in the arena must be at least 16 years of age. Younger persons may still be permitted to hand out trophies.

Headphones or any other communication devices are not allowed on riders while competing in events at the State Show.

A contestant will receive 3 calls to be in the arena and will then be allowed 1 minute to be in the pen.

No mules will be allowed.

Only the FIRST PLACE horse in an event will be allowed a victory lap

### TIMER FAILURE

In the event of timer failure, a contestant may have a choice regarding time for his/her re-ride; he/she may run immediately, or following his/her association line-up, or following another complete association line-up. Should he/she be the last rider in the event when the timer fails, he/she will then be given five (5) minutes to rest his/her horse.

If a rider makes a qualified run in any speed event and the timer fails to work properly, the rider must make a bona fide attempt in the re-ride and will still receive time event though an automatic disqualification would normally apply. NOTE: Deliberate and intentional disqualification to achieve a fast time will not be tolerated, and the decision of the judge will be final.

### ANNOUNCER'S STAND

No one will be permitted upstairs in the announcer's stand unless he/she is wearing a "Show Official" badge or has the verbal permission of the Chairman, Vice Chairman, or Secretary. The walkway will be guarded to protect this rule. The Secretary shall issue badges to each association in its show packet for selected workers who will be working upstairs. These badges are to be returned to the Secretary when the association/s shift is finished.

Any messages which need the attention of the workers upstairs in the announcer's stand will be delivered via the guard or by an assigned worker.

### DRUG POLICY

1. Any injection of a stimulant, tranquilizer, or depressant which would affect or could affect a horse's performance at the Arkansas State Horse Show is prohibited. In addition, any use of a masking agent to attempt to hide one of the above mentioned drugs shall be considered the same as stimulant, tranquilizer, or depressant since it makes it impossible to test from the drugs (option B of Section 7 is required).
2. The exhibitor and owner of said horse are each responsible for a horse's condition, and presumed to know all rules and regulations of the Association and the penalty provision rules. Such individuals' voluntary act of entering, exhibition, or causing the exhibited a horse in the show makes them eligible for disciplinary sanctions, whether or not the persons had actual knowledge of the presence of the foreign substance or drug.
3. The Arkansas State Horse Show Board of directors will hire a licensed veterinarian to conduct random testing. As of the 2004 State Horse Show, drug testing will no longer be

done for each class. The computer will randomly choose which classes will be tested. No one will know which classes will be tested prior to this. In the speed classes, chosen, the first place horse and one other horse will be tested and in the judged events the first place horse and two other horses will be tested. The method of testing will be through a urine sample following an injection of lasix. If an owner/exhibitor prefers other means of testing, he/she may choose one of the options listed below.

- a. The horse may urinate naturally; if this is done, 50 cc of urine must be provided to the lab for testing purposes. If this choice is made, the horse must remain in a stall in the testing area until there is sufficient urine for testing. Veterinarian discretion will be used here.
- b. The horse may be given a blood test; if this choice is made by the owner/exhibitor, he/she must pay a \$75 deposit and be solely responsible for the balance of the blood test. If the deposit is more than the charge made by the lab, the balance of the deposit will be refunded to the owner/exhibitor.

If any of the above specifications are not met, the owner and exhibitor will receive a one-year suspension from the Arkansas State Horse Show; they also will not be allowed to show at any further State Shows until the balance of the charge due for the testing is paid.

4. All medications administered to a horse within seven (7) days showing must be reported to the testing vet. Any permissible drug must be covered by a written statement from a private vet to the testing vet by the owner/exhibitor. Any permissible drug that is given with an agent that can act as a masking agent or is capable of altering a test sample must be reported to the testing vet and also be covered by a letter from a private vet. It is also the owner/exhibitor's responsibility to insure the testing vet makes note of such drug on testing form to be submitted to the lab.

5. It is the exhibitor's responsibility to take his horse that is to be tested immediately following the event to the test area or the owner/rider will suffer consequences. Until the testing is completed, the horse must be in the testing area.

6. The following will be appropriate punishments for drug related offenses:

- a. Failure to provide a written statement or notification to the testing vet of a permissible drug will result in (1) the exhibitor or owner paying the entire cost of the drug test, and (2) exhibitor and owner being banned from showing the first three of their association shows. Failure to pay for the test within 90 days after notification will result in the owner and exhibitor being suspended from the next State Show: they will also not be allowed to show at any future State Show until the balance of the charge due for the testing is paid.

- b. Presence of an illegal drug will result in (1) exhibitor and owner being suspended from all State Association shows and the ASHSA Championship Show for one year, and (2) owner and exhibitor paying for the test conducted on horses found to be positive. Failure to pay for the test within 90 days after notification will cause expulsion from future State Shows until the charge is paid.
- c. Failure to submit to a drug test will result in the exhibitor and owner receiving the same punishment as that listed in Section 7B for horses found to contain illegal drugs.
- d. Drug related offences can also be misconduct and fall under sportsmanship rules.

7. The following persons will serve as the ASHSA Drug Committee: ASHSA Chairman, ASHSA Vice Chairman, testing vet and immediate past ASHSA Chairman. This committee will be responsible for the following.

- a. Making any additional decisions related to drug tests and
- b. Serving as an Appeals Committee: NOTE: All appeals must be made in writing to this Committee.

8. Any person wishing to appear before the ASHSA Board of Directors to appeal disciplinary action taken against them under the Drug Policy Rules must post a \$250.00 cash bond to the Board prior to appearing. This bond will be refunded if the Board of Directors rules in favor of the appellant.

### COGGINS

There shall be a negative Coggins required at the State Show. The Coggins test paper shall be dated within 12 months of the Arkansas State Horse Show and shall show that the test was performed during this same time span.

### MANDATORY CLASSES

- 1. Barrel Pick-up
- 2. Boys Western Pleasure
- 3. Buckaroo Barrels
- 4. Buckaroo Horsemanship
- 5. Buckaroo Pole Bending
- 6. Girls' Western Pleasure
- 7. Junior Barrels
- 8. Junior Flags
- 9. Junior Horse Pleasure
- 10. Junior Pole Bending
- 11. Junior Reining
- 12. Junior Speed Race
- 13. Keyhole Race

14. Ladies' Gaited Pleasure
15. Men's Gaited Pleasure
16. Pony Barrels
17. Pony Pole Bending
18. Pony Under Saddle
19. Queen's Class
20. Senior Barrels
21. Senior Flags
22. Senior Pole Bending
23. Senior Reining
24. Senior Speed Race
25. Senior Western Pleasure (Ladies')
26. Senior Western Pleasure (Men's)
27. Slow Gaited Pleasure
28. Two-Year-Old Snaffle Bit Pleasure
29. Walk Trot
30. Youth Horsemanship
31. Hunter Under Saddle

NOTE: Unless otherwise specified, current AQHA rules will apply to those classes covered in the AQHA Rule Book.

## JUDGED EVENTS

### GENERAL INFORMATION

1. AQHA rules will prevail unless otherwise indicated.
2. Numbers are to be worn on the saddle pads in all judged events. Competitors in Ladies' Gaited, Men's Gaited, and Hunter Under Saddle have the option of either wearing their numbers on the back or on their saddle pads.
3. All riders with the exception of Ladies' Gaited Pleasure must wear hats in judged events. The wearing of hats in Ladies' Gaited Pleasure is optional.
4. Cuts for working all judged classes will be drawn in advance. Any contestant who enters the arena during a cut other than the one he/she has assigned will be suspended from riding in the class.
5. When there are 45 or more riders in an event, there must be 3 cuts.

6. A limit of 25 horses may show in the finals of a class/ if there are more than 25 eligible, semi-finals must be held in the class.

### QUEEN'S CLASS

Must be 21 years and under. Married, widowed, or divorced contestants are not eligible. Must be female at birth and must have never given birth to a child. The judge shall judge as follows: 50% on appearance, 30% on rider horsemanship and 20% on horse.

### PONY UNDER SADDLE

Ponies are to be 52 inches and under. Each association president is to insure each pony is within size limit before sending entries to State. Ponies will be measured on same surface, with the same measuring device which shall be measured while standing squared up and shall not be measured in any other position. Any pony failing to measure 52" or under will be disqualified and marked, and will not be allowed to compete in any pony events during the state show. Ponies will not be re-measured if they are disqualified. AQHA rules will apply, except the Western Pleasure pony will not be required to back. Ponies must be ridden 1 handed.

### HORSEMANSHIP (Buckaroo and Youth)

Horses will work a pattern first. The pattern must be posted at least 30 minutes prior to the class. The finalists will return to work on the rail; the top 15 scores and all ties will be taken back to this final rail work.

### REINING

Current AQHA rules and patterns will apply. Junior horses shown in Reining may be ridden two-handed. The selection of patterns will be at the discretion of the Board. Scores will be announced as a rider completes his/her pattern. If a tie results in the top ten places in reining and the same score has been given by both judges, then a work-off must be held. The judge's score sheet is to be turned into the State Secretary and will be double checked and maintained as part of the official records. A copy will be posted following the class. Working positions will be drawn rather than having these persons work as associations. Arena will be drug between every 10 riders.

### WESTERN PLEASURE

AQHA rules will apply. Only one hand may be used unless otherwise specified. Horses shown in 2 Yr. Old Snaffle Bit may be shown in Jr. Horse Pleasure at the discretion of the rider at the same show. (Refer to page 173 AQHA Handbook). Backing on the rail will be at the discretion of the judges.

### JUNIOR HORSE PLEASURE

1. No horse that will be older than five (5) years of age during the current calendar year shall be allowed to participate.
2. Age of horses entered will be the responsibility of the respective association presidents and will be checked only on protest. A veterinarian will be present during this class to settle any age dispute and his discretion will be accepted as final.
3. Junior horse competing in any judged event (excluding slow gaited) may be shown with a non-mechanical hackamore or snaffle bit to AQHA regulation. May also be ridden with two hands on reins.

### TWO YEAR OLD SNAFFLE BIT PLEASURE

A 5 minute warm-up period will be allowed for this class prior to each cut and the finals.

1. Horses that have been previously shown in anything other than a snaffle bit or bosal are ineligible.
2. Horses are to be shown in standard, plain, or silver headstalls (browband, shaped ear or split ear), smooth snaffle bit with broken mouthpiece (conventional) ring, egg butt, or D-ring, with ring no larger than 4" (four) and no smaller than 2" (two) from the cheek to 1" (one) inch from the cheek. Bit must be a minimum 3/8" diameter with a gradual decrease to the center of the snaffle. A loose curb strap (leather or nylon only) is optional and must be attached below the reins.
3. Reins are to be attached above the curb strap.
4. Standard, leather, or woven, split reins are mandatory. Hair reins are not permitted with snaffle bits.
5. A braided rawhide or leather bosal may be used in lieu of a snaffle bit, no larger than 3/4" diameter at the check; there must be a minimum of 1-finger space (approximately 3/4") between the bosal and nose. Absolutely no metal can be under the jaw or on the noseband in connection with the bosal. The bosal should be properly fitted relative to the horse's size and conformation.
6. All entries must be shown with both hands on reins, maintaining light contact with the horse's mouth. The rider's hands should be visible to the judges at all times. Reins must be crossed with the tails of reins on the opposite side of the neck.

7. All horses must be judged as a pleasure horse at the walk, jog, lope, and back as on all transitions between gaits. Horses must work both ways of the ring at three gaits. The judge may at his/her discretion require the back of only the finalists in the class. Horses must reverse to the inside (away from the rail). They may be required to reverse at the walk or jog, at the discretion of the judge, but shall not be asked to reverse at the lope or asked to extend the jog.

8. Horses are not to be called into the center of the arena from a jog or a lope.

9. A tight rein or excessive slack is at no time acceptable. Head carriage should be quiet or natural.

10. If a horse's mouth shows signs of broken skin, rawness, or bleeding, the horse will be eliminated from competition. If a horse's nose or any area touched by the bosal shows signs of broken skin, rawness, or bleeding, the horse will be eliminated from competition.

11. The following measurements should be used for gaits:

a. The walk should be comfortable, flat, and ground covering.

b. The jog should be soft, relaxed, and quiet with a definite two beat. At no time should it resemble a running walk nor should it be rough and stilted.

c. The lope should be rolling and comfortable with strong emphasis on a natural 3-beat, soft lope.

12. Horses should back on command quietly, willingly, and easily in a straight line without resistance, jawing, delay, and tossing of head.

### GAITED PLEASURE

1. Horse is to be shown at a walk and favorite gait. Horses will enter the arena at a walk.

2. English or western equipment may be used.

3. The class will be judged on the performance and conformation of the horse at the discretion of the judge.

4. Open shoeing of the horse is allowed. A period of 7 minutes will be allowed for re-shoeing or tack repair.

5. A rest period not to exceed 10 minutes will be allowed for the last work off.

6. The wearing of hats is optional for ladies, the wearing of hats is mandatory for men.

7. One or both hands may be used on the reins.
8. Action devices are prohibited. Protective boots made of soft rubber or leather will be allowed but not to exceed 6 ounces in weight.
9. Gaited horses will not be asked to back up.
10. Beginning with the 2005 State Show a DQP will be used to check all gaited horses prior to being shown in their class.
11. Bits with shanks in excess of 9 1/2" in length are prohibited. Shanks are measured from the very top of the metal to the very bottom of the metal including the rings to which the cheeks and reins are attached. See bit diagram page 24.

#### SLOW GAITED PLEASURE

1. Horse should be shown with a light rein at a flat trail walk (**NO SHOW WALK**) and a moderate rein at a favorite gait. Horses will enter the arena at a walk.
2. The horse should give the rider a pleasant ride with true road and trail qualities. It should be well-mannered and responsive to the rider, displaying soundness, quality, and the ability to stand quietly.
3. The Slow Gait favorite gait will be a comfortable, smooth gait displaying no stress on horse or rider.
4. Dress will be western, with exhibitors expected to present themselves in a professional manner.
5. Slow Gaited riders must use Western tack only and horses will be shown with split reins with reins lying on one side. No colored brow bands or ribbons are permitted. Any standard horse bit may be used, except for gag bit with no shanks. Shanks in excess of 9 1/2 " in length are prohibited. Shanks are measured from the very top of the metal to the very bottom of the metal, including the rings to which the cheeks and reins are attached. See bit diagram page 24.
6. No cavesons or nose bands of any kind will be permitted.
7. Shoes will be steel-to-foot (flat shod). Horses will be shod with one steel shoe with the frog exposed.

## **8. EXCESSIVE SPEED IN THIS CLASS WILL BE PENALIZED.**

9. Horses in Slow Gaited will not be asked to back.

### WALK-TROT

The rider will be ten (10) years old or younger, and the horse must be over fifty-two (52) inches in height. The horse will be judged at a walk and a trot and will not be asked to back. Except for these considerations, the class will be judged as a Western Pleasure class.

### OPEN HUNTER UNDER SADDLE

1. AQHA rules will apply. Points in this class will apply to the rider's age according to the age divisions listed in this rule book.

2. Horses are to be shown under saddle, not to jump.

3. Hunters under saddle should be suitable to purpose. They should move in a long, low frame and be able to lengthen their stride and cover ground, as in traversing hunt country following hounds. They should be obedient, alert, and responsive to their riders. Quick, short strides should be penalized. Horses which move in an artificial frame and are over-flexed and behind the bit should also be penalized. Horses should be serviceably sound. Judges should emphasize free movement and manners. This class will be judged on the performance, condition, and conformation of the horse; however, a minimum of 20 percent of the judging shall be based on condition and conformation.

4. Horses are to be shown at a walk, trot, and canter both ways of the ring. Horses should back easily and stand quietly.

5. Horses may change gaits at the flat foot walk or the trot at the judge's discretion. Light contact with the horse's mouth is recommended.

6. In all English classes, exhibitors and judges should bear in mind that, at all times, entrants are being judged on ability rather than on personal attire. However, riders should wear hunt coats in traditional hunt seat style and conservative color, breeches of traditional shade of buff, gray, or rust (or jodhpurs), high English boots or jodhpur shoes. Black, navy blue, or brown hunting cap is mandatory. A tie or choker is required. Spurs of unroweled type, crops, or bats are optional. Hair must be neat and contained (as in a net or braid). Judges must penalize contestants who do not conform.

## SPEED AND TIMED EVENTS GENERAL INFORMATION

### **All ties in running events will be broken by a run off.**

1. Two electric timers will be in operation at all times during speed events. The second clock will be read only in case of malfunction of the first timer.
2. If a rider makes a qualified run and the timers fail to work properly, the rider must make a bona fide attempt in the re-ride and will still receive a time even if his new run would case him to get a no-time (i.e. barrel or pole knocked down or flag missed).
3. Deliberately attempting to break the beam of the clock in any timed event in an unsportsmanlike manner will be dealt with accordingly. Use of tack, equipment, etc., to break the beam to obtain a faster time will be considered unsportsmanlike and will result in an unqualified run.
4. It shall be left to the discretion of the Chairman to rake or drag the arena if needed other than at designated times.
5. Barrels for barrel races, flag races, and speed races shall be moved to the most suitable places decided upon by the Chairman.
6. Riders may be assisted in all speed events.
7. Speed riders must wear a short with sleeves and it must be long enough to be tucked in. Contestants violating this attire will be disqualified.
8. No restraints other than rubber bands on the contestant's feet will be allowed in speed events.

### **BARREL RACE**

1. AQHA rules will apply except concerning apparel of the riders and assistance into the arena.
2. Horse and rider may enter from either side as long as pattern is not broken, and exit is made between two front barrels.
3. No barrel shall be placed closer than 15 feet from the fence.

4. Knocking over a barrel will result in disqualification.
5. Touching of the barrel by the rider is permissible.
6. If a rider makes a qualified run in this event and the timer fails to work properly, the rider must make a bona fide attempt in the re-ride and will receive a time even if a barrel is knocked down. NOTE: Deliberate and intentional knocking down of a barrel in order to receive a faster time will not be tolerated, and the decision of the judge will be final.
7. For a re-ride time due to timer failure, see **TIMER FAILURE**.

### POLE BENDING

1. AQHA rules will apply except concerning apparel of the riders and assistance into the arena.
2. The pole bending pattern is to be run around six (6) poles. Each pole is to be twenty-one (21) feet apart and the first pole is to be at least twenty-one (21) feet from the starting line with the last pole at least twenty (20) feet from the fence.
3. Failure to follow the pattern shall cause disqualification.
4. Touching of a pole by rider is permitted and will not result in disqualification.
5. If a pole is knocked over, the rider will be disqualified.
6. If a rider makes a qualified run in this event and the timer fails to work properly, the rider must make a bona fide attempt in the re-ride and will still receive a time even if a pole is knocked over. NOTE: Deliberate and intentional knocking over a pole in order to receive a faster time will not be tolerated, and the decision of the judge will be final.
7. For re-ride time due to timer failure, see **TIMER FAILURE**.

### FLAG RACE

1. Horse and rider may enter from either side as long as pattern is not broken. (See diagram on page 22).
2. Flags will be 18” long with 8” by 9” cloth rag. A 1-inch dowel must be used as a flag handle. Flag may be used as a quirt. Flag is to be marked 3” from the bottom for guideline for placement in bucket.

3. Buckets will be plastic of any color. Two (2) five (5) gallon-size buckets filled to three (3) inches from the top of the bucket. The three (3) inches will be marked with a line. Masonry sand is to be used. The bucket must be placed on the inside of the barrel. The barrel holding the bucket will be placed 40 feet from the timer. The end barrel will be 126 feet from the timer.
4. The sand in the buckets will be poured into new buckets between drags. If sand is lost, new sand can be added at the discretion of the chairman.
5. Upon completion of the ride, barrels and buckets must be standing upright. Flag must be in sand first inside bucket, not from outside in.
6. If any barrel or bucket is knocked over, the rider will be disqualified.
7. In the event of malfunction of the timer, the rider must run again making a bona fide attempt in the re-ride and will receive a time even if the rider fails to stick the flag. NOTE: Deliberate and intentional illegal procedures executed in order to receive a faster time will not be tolerated, and the decision of the judge will be final.
8. For re-ride time due to timer failure, see TIMER FAILURE.
9. End barrel must be set in same position as for barrel race.
10. Barrels may be moved back and forth a certain distance to alleviate area around barrels becoming dug out or dangerous.
11. Judge will place flag in center of pickup bucket.

#### JUNIOR/SENIOR SPEED RACE

1. Horse and rider may enter from either side as long as pattern is not broken. (See Speed Race Diagram page 23.)
2. Rider will be disqualified if barrel is knocked over during run.
3. In the event of malfunction of the timer, the rider must run again making a bona fide attempt in the re-ride to receive a time. NOTE: Deliberate and intentional illegal procedures executed in order to receive a faster time will not be tolerated, and the decision of the judge is final.
4. For re-ride time due to timer failure, see TIMER FAILURE.

### KEYHOLE RACE

1. Keyhole shall consist of a 12 foot circle with a 10 foot long by a 5 foot wide throat (10 ft. X 5 ft.). See Keyhole Race diagram page 23.
2. Horse may enter pattern with a flying start. This is a timed event. Keyhole used will be outlined in white line. Horse will follow directions as indicated in diagram.
3. Horse must turn in circle – not in throat or approach to circle.
4. If a horse steps on or over a line, it will be disqualified, and no time will be given on the ride.
5. Judge must stand behind the keyhole or to the side at a safe distance.
6. In the event of malfunction of the timer, the rider must run again making a bona fide attempt in the re-ride to receive a time. NOTE: Deliberate and intentional illegal procedures executed in order to receive a faster time will not be tolerated and the decision of the judge is final.
7. For re-ride time due to timer failure, see TIMER FAILURE.

### BARREL PICK-UP

1. A contestant may enter only one time in the class, either as a rider or as a jump man but not as both.
2. This race is to be run with a barrel at the opposite end of the arena at least 20 feet from the fence, and the rider may ride to the right or left circling the barrel.
3. For safety of riders in this class, the barrel is to be moved ten feet if necessary and is to be left to the discrimination of the Chairman.
4. The starting line should be at least 20 feet inside the arena.
5. The jump man must mount from the barrel and must be astraddle of the horse at the finish line.
6. Persons being picked up must mount unassisted. Use of the rider's hands at any time during the ride is not allowed and will result in disqualification.

7. If the jump man touches the ground, it will be a disqualification.
8. The judge is to be on the ground in back of the barrel so as to have a better view.
9. In the event of malfunction of the timer, the rider must run again making a bona fide attempt in the re-ride to receive a time. NOTE: Deliberate and intentional illegal procedures executed in order to receive a faster time will not be tolerated and the decision of the judge is final.
10. For re-ride time due to timer failure, see TIMER FAILURE.

### PONY BARRELS AND POLES

1. Ponies are to be 52 inches and under. Each association president is to insure each pony is within size limit before sending entries to State. Ponies will be measured on a flat surface as designated by the official vet. All ponies will be measured on same surface, with the measuring device which shall leave a vertical and horizontal bubble level. All ponies shall be measured while standing squared up and shall not be measured in any other position. Any pony failing to measure 52” or under will be disqualified and marked, and will not be allowed to compete in any pony events during the state show. Ponies will not be re-measured if they are disqualified.
2. The rider must be ten (10) and under.
3. Riders in pony classes cannot ride ponies in any class where there is a specified pony class.
4. Riders over ten (10) years may ride a pony in their age division.
5. Participants who ride in Pony Barrels and Pony Poles cannot ride in Buckaroo Barrels and Buckaroo Poles.
6. Rules for each class will be the same as those for regular barrels and poles.

## FLAGS DIAGRAM

CROSS TIMER  
PICK UP FLAG 1  
TURN BARREL  
STICK FLAG 2  
CROSS TIMER

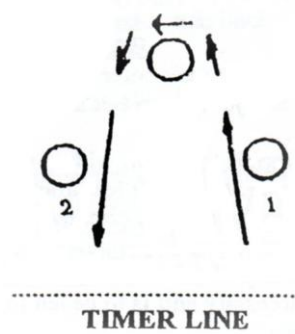

## SPEED DIAGRAM

CROSS TIMER  
TURN BARREL  
AND RUN TO  
TIMER LINE

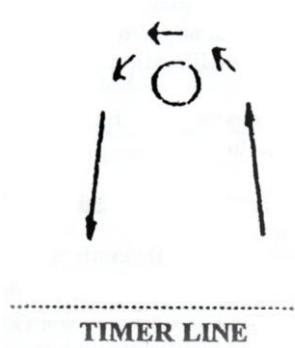

## KEYHOLE DIAGRAM

CROSS TIMER  
ENTER KEYHOLE  
TURN AROUND IN  
CIRCLE EXIT KEYHOLE  
CROSS TIMER

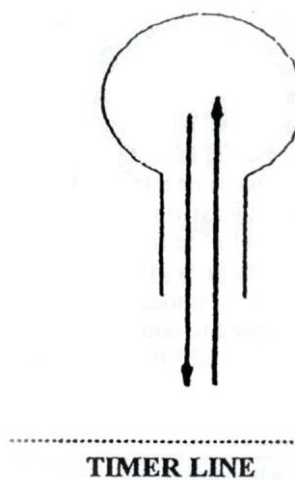

## BIT MEASUREMENT

Maximum Shank Length = 9 1/2 inches

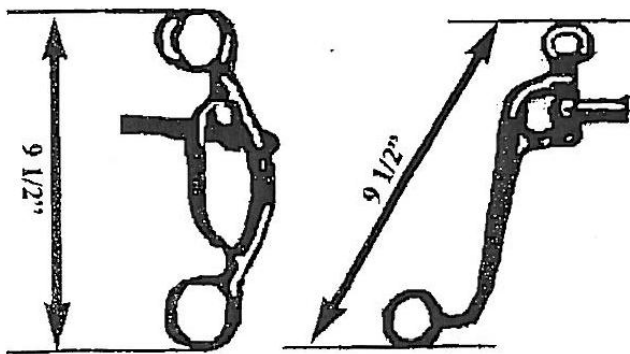

19

## REINING PATTERN NUMBER 1

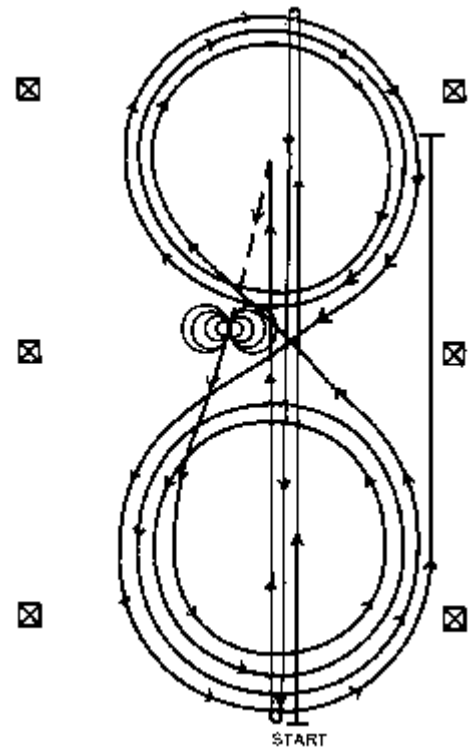

1. Run at speed to the far end of the arena past the end marker and do a left rollback – no hesitation.
2. Run to the opposite end of the arena past the end maker and do a right rollback – no hesitation.
3. Run past the center marker and do a sliding stop. Back up to center of the arena or at least ten feet. Hesitate.
4. Complete four spins to the right.
5. Complete four and one-quarter spins to the left so that horse is facing left wall or fence. Hesitate.
6. Beginning on the left lead, complete three circles to the left: the first circle large and fast; second circle small and slow; the third circle large and fast. Change leads at the center of the arena.
7. Complete three circles to the right: the first circle large and fast; the second circle small and slow; the third circle large and fast. Change leads at the center of the arena.

8. Begin a large fast circle to the left but do not close this circle. Run straight up the right side of the arena past the center marker and do a sliding stop at least twenty feet from wall or fence. Hesitate to demonstrate the completion of the pattern.

Rider may drop bridle to the designated judge.

### REINING PATTERN 2

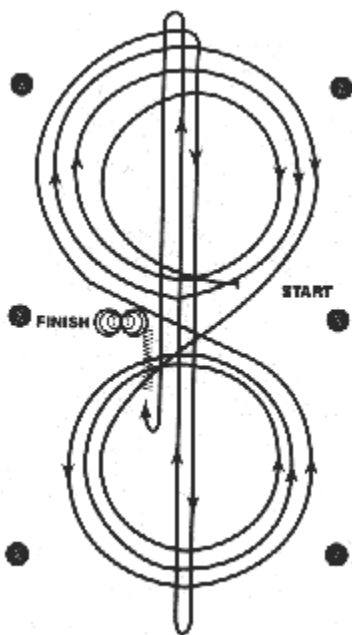

Beginning at the center of the arena facing the left wall or fence

1. Beginning on the right lead, complete three circles to the right; the first circle small and slow; the next two circles large and fast. Change leads at the center of the arena.
2. Complete three circles to the left; the first circle small and slow; the next two circles large and fast. Change leads at the center of the arena.
3. Continue around previous circle to the right. At the top of the circle, run down the middle to the far end of the arena past the end marker and do a right rollback – no hesitation.
4. Run up the middle to the opposite end of the arena past the end marker and do a left rollback – no hesitation.
5. Run past the center mark and do a sliding stop. Back up to the center of the arena or at least ten feet. Hesitate.
6. Complete four spins to the right.
7. Complete four spins to the left. Hesitate to demonstrate the completion of the pattern.

Rider may drop bridle to the designated judge.

## REINING PATTERN NUMBER 3

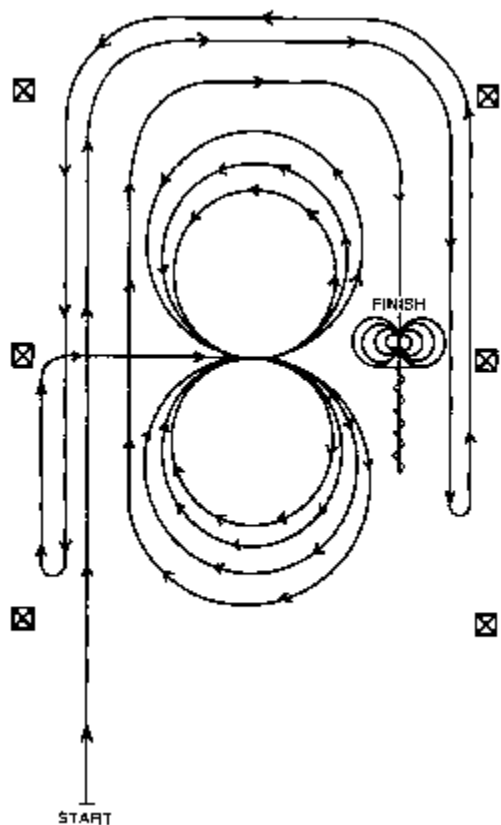

1. Beginning, and staying at least twenty feet from the walls or fence, lop straight up the left side of the arena, circle the top end of the arena, run straight down the opposite or right side of the arena past the center marker and do a left rollback – no hesitation.
2. Continue straight up the right side of the arena staying at least twenty feet from the walls or fence, circle back around the top of the arena, run straight down the left side of the arena past the center marker and do a right rollback – no hesitation.
3. Continue up the left side of the arena to the center marker. At the center marker, the horse should be on the right lead. Guide the horse to the center of the arena on the right lead and complete three circles to the right; the first two circles large and fast; the third circle small and slow. Change leads at the center of the arena.
4. Complete three circles to the left; the first two circles large and fast; the third circle small and slow. Change leads in the center of the arena.
5. Begin a large fast circle to the right but do not close this circle. Continue up the left side of the arena staying at least twenty feet from the walls or fence, circle the top of the arena,

run straight down the opposite or right side of the arena past the center marker and do a sliding stop. Back up at least 10 feet. Hesitate.

6. Complete four spins to the right.

7. Complete four spins to the left. Hesitate to demonstrate completion of the pattern.

Rider may drop bridle to designated judge.

#### REINING PATTERN NUMBER 4

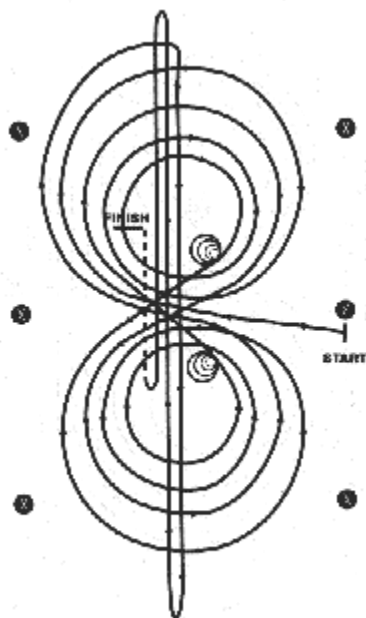

Beginning at the center of the arena facing the left wall or fence

1. Beginning on the right lead, complete three circles to the right; the first two circles large and fast; the third circle small and slow. Stop at the center of the arena.

2. Complete four spins to the right. Hesitate.

3. Beginning on the left lead, complete three circles to the left; the first two circles large and fast; the third circle small and slow. Stop at the center of the arena.

4. Complete four spins to the left. Hesitate.

5. Beginning on the right lead, run a large fast circle to the right, change leads at the center of the arena. (Figure 8).

6. Continue around previous circle to the right. At the top of the circle, run down the middle to the far end of the arena past the end marker and do a right rollback – no hesitation.

7. Run up the middle to the opposite end of the arena past the end marker and do a left rollback – no hesitation.

8. Run past the center marker and do a sliding stop. Back up to the center of the arena or at least ten feet. Hesitate to demonstrate completion of the pattern.

Rider may drop bridle to the designated judge.

## REINING PATTERN NUMBER 5

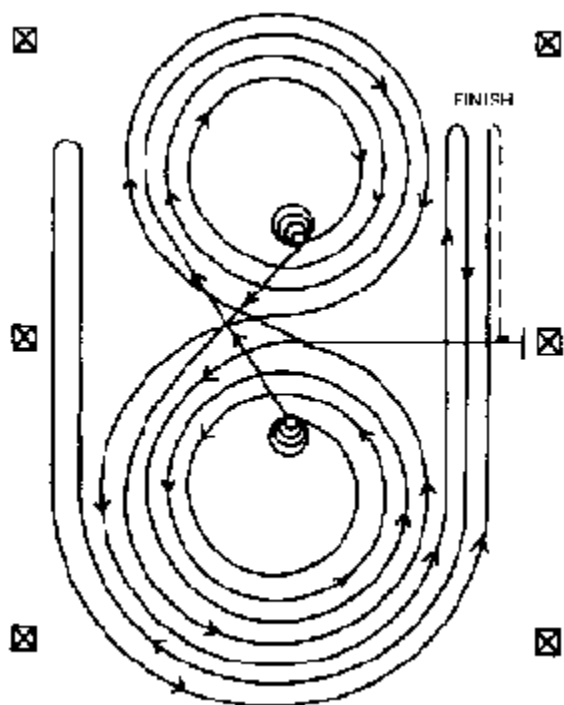

Beginning at the center of the arena facing the left wall or fence

1. Beginning on the left lead, complete three circles to the left; the first two circles large and fast; the third circle small and slow. Stop at the center of the arena.
2. Complete four spins to the left. Hesitate.
3. Beginning on the right lead, complete three circles to the right; the first two circles large and fast; the third circle small and slow. Stop at the center of the arena.
4. Complete four spins to the right. Hesitate.
5. Beginning on the left lead, run a large fast circle to the left, change leads at the center of the arena, run a large fast circle to the right, and change leads at the center of the arena.
6. Continue around previous circle to the left but do not close this circle. Run up the side of the arena past the center marker and do a right rollback at least twenty feet from the wall or fence – no hesitation.
7. Continue around previous circle but do not close this circle. Run up the left side of the arena past the center marker and do a left rollback at least twenty feet from the wall or fence – no hesitation.

8. Continue back around previous circle but do not close this circle. Run up the right side of the arena past the center marker and do a sliding stop at least twenty feet from the wall or fence. Back up at least ten feet. Hesitate to demonstrate completion of the pattern.

Rider may drop bridle to the designated judge.

### REINING PATTERN 6

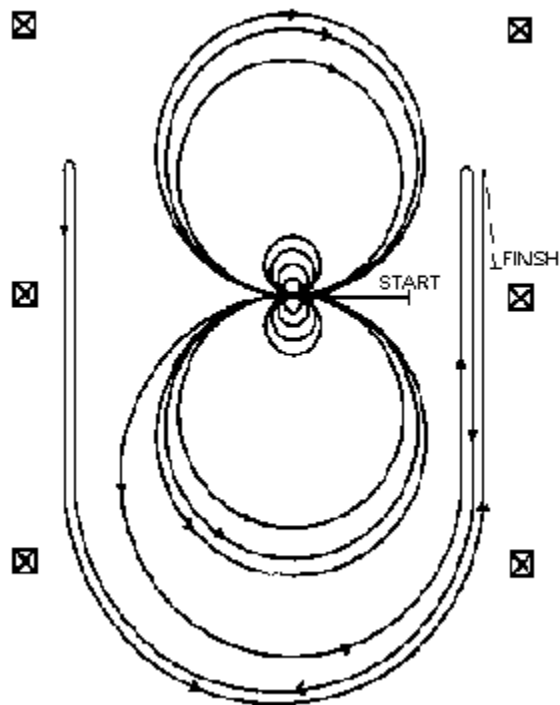

Beginning at the center of the arena facing the left wall or fence

1. Complete four spins to the right.
2. Complete four spins to the left. Hesitate.
3. Beginning on the left lead, complete three circles to the left; the first two circles large and fast; the third circle small and slow. Change leads at the center of the arena.
4. Complete three circles to the right. The first two circles large and fast the third circle small and slow. Change leads at the center of the arena.
5. Begin a large fast circle to the left but do not close this circle. Run up the left side of the arena past the center marker and do a right rollback at least twenty feet from the wall or fence – no hesitation.
6. Continue back around previous circle but do not close this circle. Run up the left side of the arena past the center marker and do a left rollback at least twenty feet from the wall or fence – no hesitation.

7. Continue back around previous circle but do not close this circle. Run up the right side of the arena past the center marker and do a sliding stop at least twenty feet from the wall or fence. Back at least ten feet. Hesitate to demonstrate the completion of the pattern.

Rider may drop bridle to the designated judge.

### REINING PATTERN NUMBER 7

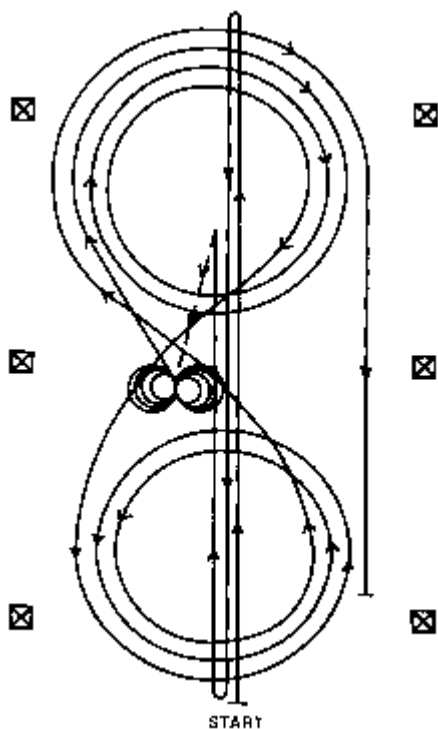

1. Run at speed to the far end of the arena past the end marker and do a left rollback – no hesitation.
2. Run to the opposite end of the arena past the end marker and do a right rollback – no hesitation.
3. Run past the center marker and do a sliding stop. Back up to the center of the arena at least ten feet. Hesitate.
4. Complete four spins to the right.
5. Complete four and one-quarter spins to the left so that the horse is facing left wall or fence. Hesitate.
6. Beginning on the right lead, complete three circles to the right; the first two circles large and fast; the third circle small and slow. Change leads at the center of the arena.
7. Complete three circles to the left; the first two circles large and fast; the third circle small and slow. Change leads at the center of the arena.

8. Begin a large fast circle to the right but do not close this circle. Run straight down the right side of the arena past the center marker and do a sliding stop at least twenty feet from the wall or fence. Hesitate to demonstrate the completion of the pattern.

Rider may drop bridle to the designated judge.

### REINING PATTERN NUMBER 8

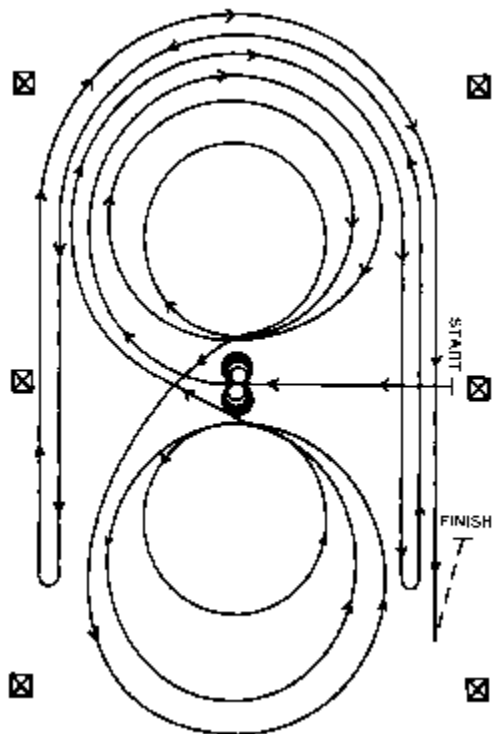

Walk horse to center of the arena facing the left wall or fence.

1. Complete four spins to the left.
2. Complete four spins to the right. Hesitate.
3. Beginning on the right lead, complete three circles to the right: the first circle large and fast; the second circle small and slow; the third circle large and fast. Change leads at the center of the arena.
4. Complete three circles to the left: the first circle large and fast; the second circle small and slow; the third circle large and fast. Change leads at the center of the arena.
5. Begin a large fast circle to the right but do not close this circle. Run straight down the right side of the arena past the center marker and do a left rollback at least twenty feet from the wall or fence – no hesitation.
6. Continue back around the previous circle but do not close this circle. Run down the left side of the arena past the center marker and do a right rollback at least twenty feet from the wall or fence – no hesitation.

7. Continue back around the previous circle but do not close this circle. Run down the right side of the arena past the center mark and do a sliding stop at least twenty feet from the wall or fence. Back up at least ten feet. Hesitate to demonstrate completion of the pattern.

Rider may drop bridle to the designated judge.

REINING PATTERN NUMBER 9

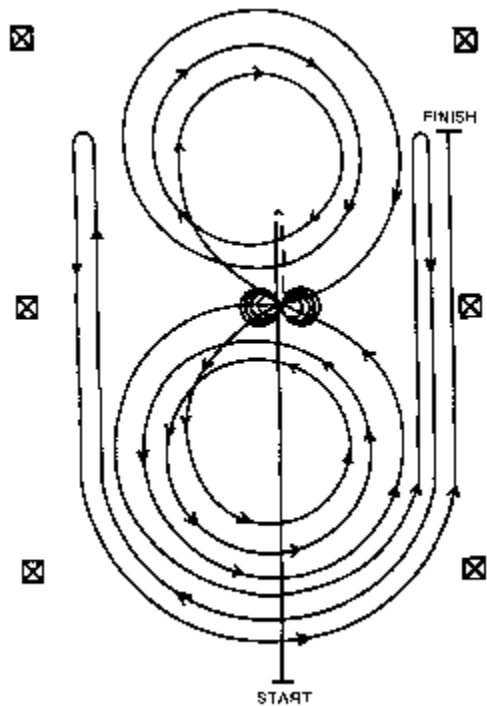

1. Run past the center marker and do a sliding stop. Back up to the center of the arena or at least ten feet. Hesitate.
2. Complete four spins to the right.
3. Complete four and one-quarter spins to the left so that horse is facing the left wall or fence. Hesitate.
4. Beginning on the left lead, complete three circles to the left: the first circle small and slow; the next two circles large and fast. Change leads at the center of the arena.
5. Complete three circles to the right: the first circle small and slow; the next two circles large and fast. Change leads at the center of the arena.
6. Begin a large fast circle to the left but do not close this circle. Run up the right side of the arena past the center marker and do a right rollback at least twenty feet from the wall or fence – no hesitation.
7. Continue back around the previous circle but do not close this circle. Run up the left side of the arena past the center marker and do a left rollback at least twenty feet from the wall or fence – no hesitation.

8. Continue back around previous circle but do not close this circle. Run up right side of the arena past the center marker and do a sliding stop at least twenty feet from the wall or fence. Hesitate to demonstrate completion of the pattern.

Rider may drop bridle to the designated judge.

### REINING PATTERN NUMBER 10

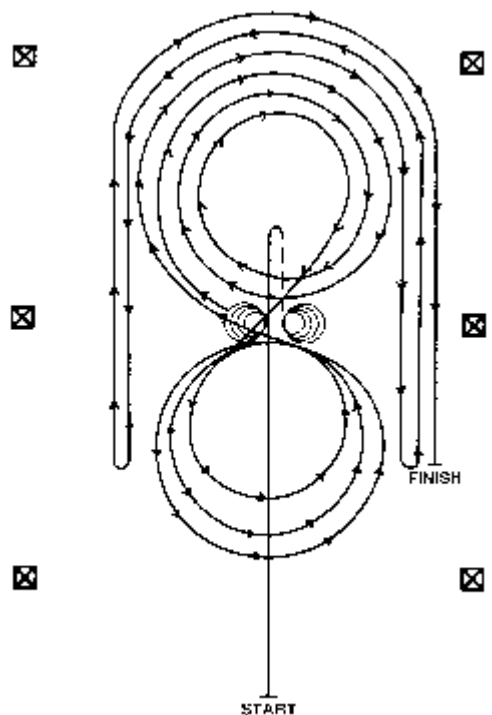

1. Run past the center marker and do a sliding stop. Back up to the center of the arena or at least ten feet. Hesitate.
2. Complete four spins to the right.
3. Complete four and one-quarter spins to the left so that the horse is facing the left wall or fence. Hesitate.
4. Beginning on the right lead, complete three circles to the right: the first two circles large and fast, the third circle small and slow. Change leads at the center of the arena.
5. Complete three circles to the left: the first circle small and slow, the next two circles large and fast. Change leads at the center of the arena.
6. Begin a large fast circle to the right but do not close this circle. Run down the right side of the arena past the marker and do a left rollback at least twenty feet from the wall or fence – no hesitation.
7. Continue back around the previous circle but do not close this circle. Run down the left side of the arena past the center and do a right rollback at least twenty feet from the wall or fence – hesitation.

8. Continue back around previous circle but do not close this circle. Run down the right side of the arena past the center marker and do a sliding stop at least twenty feet from the wall or fence. Hesitate to demonstrate completion of the pattern. Rider must dismount and drop the bridle to the designated judge.